

64ANH16

Revision 0

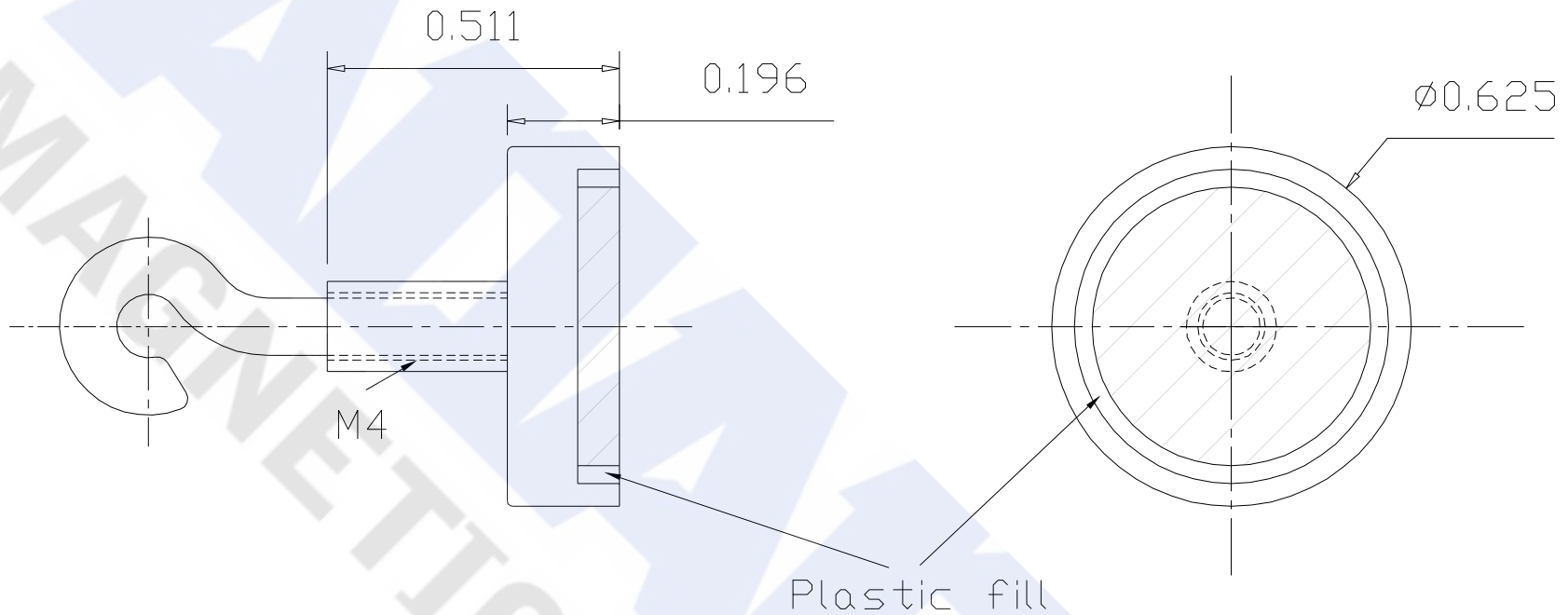

Specifications:

- 1) Neo magnet
- 2) Nickel plated steel cup with hook
- 3) Magnet and cup are glued
- 4) Pull pounds: 12 lbs min. (Tested on a clean, ground steel plate 0.375" thick)
- 5) Working temperature range: -40°C~80°C
- 6) All dimensions are inches